

<p>SN6011 1 gear motor SN6011 with incorporated control unit and plug-in receiver.</p> 	<p>FLO2R-S 1 transmitter 433.92 MHz, 2 channels.</p> 
<p>SPIN10KCE Guide (thickness 35 mm) in three 1-metre sections.</p>  <p>3 x 1 m</p>	<p>SPIN11KCE Guide (thickness 35 mm) in one 3-metre section.</p>  <p>1 x 3 m</p>

For sectional doors up to 8.8 m² and up-and-over garage doors up to 9.8 m², belt drive.

- Two versions in kit:**
- pre-assembled, **3x1 m sections guide** (SPIN10KCE)
 - **pre-assembled 3 m guide** (SPIN11KCE).

Advanced: incorporated radio card, compatible with the Nice Flo, FloR and Smilo systems: 150 transmitters can be entered! Input for photocells and possibility of connecting photo-test with self-learning function during installation.

Safe: obstacle detection system and automatic programming of the working times; motor absorption is monitored during movement, self-diagnosis by means of a flashing light and courtesy light. Acceleration and deceleration can be adjusted at the beginning and end of each opening and closing manoeuvre. Can be connected with last generation sensitive edges 8.2 KOhm.

Code	Description
SPIN10KCE	Kit for automating sectional and up-and-over doors. 3x1 m-sections linear guide
SPIN11KCE	Kit for automating sectional and up-and-over doors. 3 m pre-assembled guide

N.B. The content of the package may vary: consult the retailer.

Technical specifications

Code	SN6011
Electrical data	
Power supply (Vac 50/60 Hz)	230
Absorption (A)	0.7
Power (W)	200
Performance data	
Speed (m/s)	0.14
Force (N)	550
Work cycle (cycles/day)	30
Dimensional and general data	
Protection level (IP)	40
Working temp. (°C Min/Max)	-20 ÷ +50
Dimensions (mm)	225x330x100 h
Weight (kg)	3.3

Utilisation limits

Using the maximum travel

	Non-projecting up-and-over door		Projecting up-and-over door		Sectional	
	H	L	H	L	H	L
SPIN10KCE	2.2 m	3.5 m	2.8 m	3.5 m	2.4 m	3.7 m
SPIN11KCE	2.2 m	3.5 m	2.8 m	3.5 m	2.4 m	3.7 m

Nice recommends customers order products in pallets in order to facilitate storage and delivery, and ensure packs are uniform. The number of packs per single pallet has been specified for this reason. Approximate draft.

Sectional

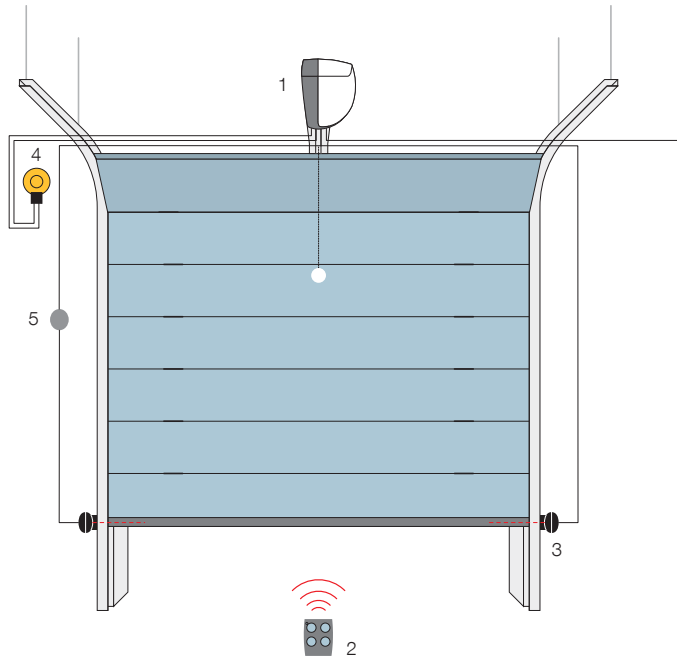

Non-projecting up-and-over door

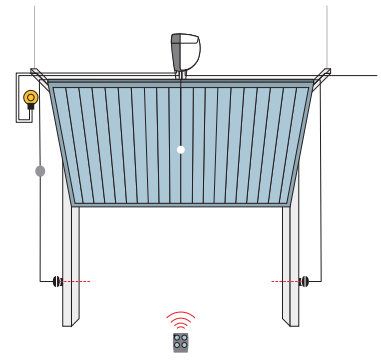

Projecting up-and-over door

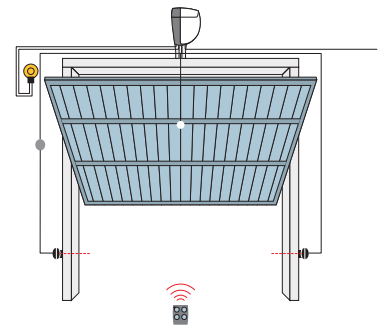

1. Spin 2. Transmitter 3. Photocells 4. Flashing light 5. Digital or key switches.

Accessories



SNA1
Spare control unit for SPIN10KCE and SPIN11KCE.



SPA2
Kit for unlocking from the outside with cable.
Pc/pack 1



SPA5
Oscillating arm sliding on bearings with optimised structure for projecting up-and-over doors.
Pc/pack 1



SPA6
Large 585 mm long connecting arm.
Pc/pack 1



SPA7
Kit of two additional fixing brackets.
Pc/pack 2



SNA16
Quick-connect brackets for ceiling mounting.
Pc/pack 10



TS
Signboard.
Pc/pack 1

